

PARK BENCH  
FOR  
7<sup>th</sup> STREET PARK

DEPARTMENT OF ENGINEERING  
CITY OF SAN BERNARDINO

GENERAL NOTES

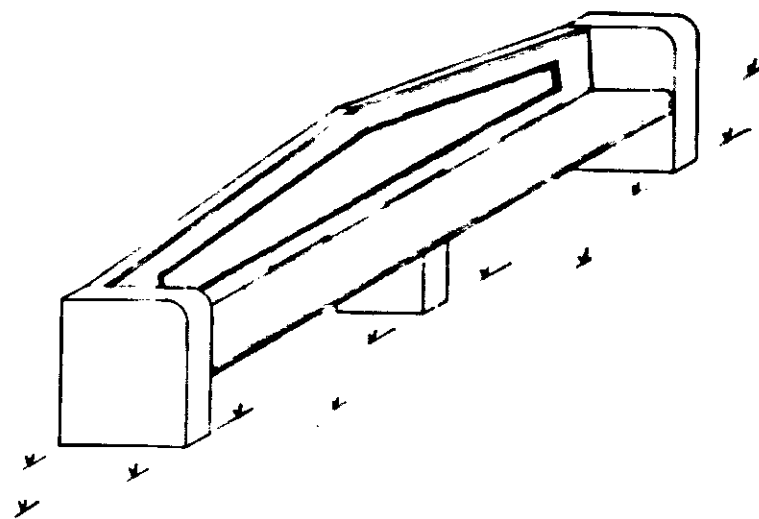

MATERIALS	
DESCRIPTION	QUANTITY
CONCRETE	.613 CY.
STEEL	34 LBS.
GROMMETS	9 EA.
DOWELS	2 EA.
A BOLTS	5 EA.
B BOLTS	4 EA.

PARK BENCH  
FOR  
7<sup>th</sup> STREET PARK

DEPARTMENT OF ENGINEERING  
CITY OF SAN BERNARDINO

GENERAL NOTES

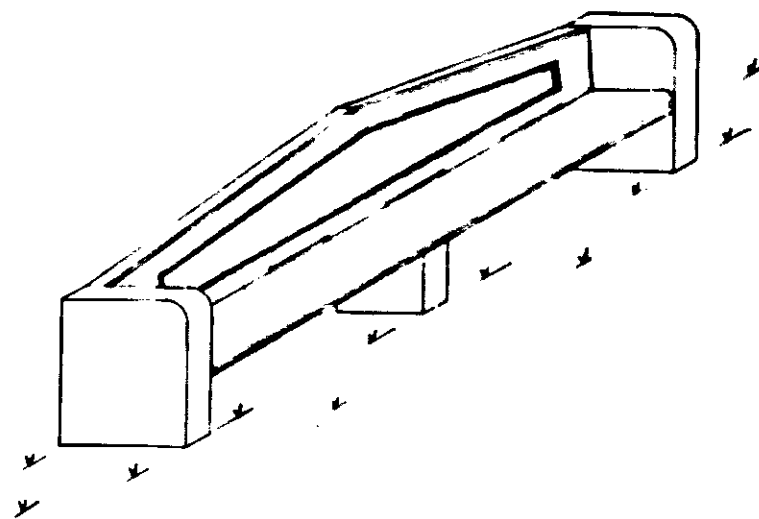

MATERIALS	
DESCRIPTION	QUANTITY
CONCRETE	.613 CY.
STEEL	34 LBS.
GROMMETS	9 EA.
DOWELS	2 EA.
A BOLTS	5 EA.
B BOLTS	4 EA.